

BMC Injection Molding Process Cycle Time Reduction

Sheila Enid Rosado Pérez
Engineering Management
Héctor J. Cruzado, PhD
Graduate School
Polytechnic University of Puerto Rico

Abstract — High cycle time is one of most common downtime in molding processes, affecting the output and the efficiency of the area. Equipment and tool condition are key to sustain a proper cycle time. This project aimed to reduce a 10% of the high cycle time of the three top offenders of a BMC molding process. For three months, a detailed equipment evaluation was completed to identify machine conditions and how they affected the molding process. Once the corrections in the equipment were completed, there was a reduction in downtime of the top three offenders of 67%, 27% and 81%, respectively with regards to high cycle time.

Key Terms — BMC material, High cycle time reduction, injection molding, injection molding process improvement

INTRODUCTION

Eaton Corporation Electrical Division is a company that is committed to improving people's life with efficient and sustainable power management technologies. Las Piedras plant is a feeder that manufactures components for residential breakers. Eaton Las Piedras is seeking to improve their injection molding process to comply with the increase of demand for their product.

Cycle time is part of the Injection Molding process that starts when the bulk molding compound (BMC) material is injected to the mold. Material properties make it perfect for electrical features fabrications, however, is not easy to mold. The proper parameters are needed to obtain conforming parts. In this case, the study is focused on how to reduce cycle time on a BMC Injection Molding process without affecting quality of the finished good.

BMC MATERIAL

Bulk molding compound (BMC) is commonly used for small electrical devices. The material is fed into the machine barrel using a screw. Injection speed and back pressure defines the part quality regarding mechanical properties or surface appearance. When less force is applied, the higher the mechanical properties will be, the faster the injection occurs the better the surface will show. Cycle time determines the proper cure time of the entire process. This feature leads a successful molding process when correct parameters are applied. Process starts in the injection unit at the machine, where material is fed and starts the curing phase. Material is injected to the mold through the barrel to the mold. The clamping unit ensure mold will not open during the injection phase. Figure 1 shows the location of injection unit and the clamping unit in a molding injection machine.

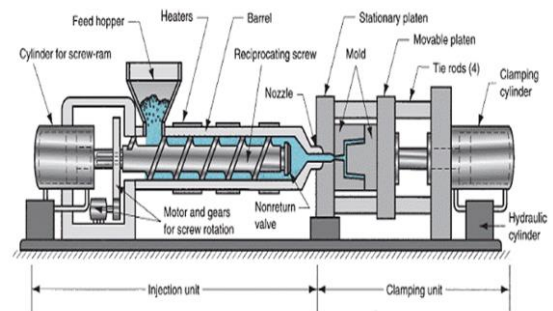

Figure 1
Injection Machine Diagram

In molding process is recommended to use the same parameters, which means that they must be defined at the validation process. Temperatures must be maintained uniform in the range of +/- 2°C [1].

Temperature uniformity is important when molding BMC material, however, a difference of 45°F can be observed in large-molded parts. In terms of cycle time, the process must consider all the aspect during the injection phase. Closing the mold in a high speed will not allow the gases to scape provoking blisters in the surface of the part. The minimum total cycle time for BMC material is 30 seconds [2].

Reduction in cycle time is a key phase in the manufacturing process and can be achieved in injection molding. This process is 3 times faster than compression molding [3]. One of the disadvantages of injection molding are the high cost of the equipment and tool versus compression machinery and molds. However, the increase in capacity due to injection molding makes this process the preferred to high volume products companies.

To implement an improved injection molding process, is important to take in consideration the following factors: use the less material the process allows to have conforming parts; be sure your equipment is up to date and your parameters are adequate for the part being mold, make sure your people is fully trained, chose the proper tool design and material for the process [4].

BASELINE

Downtime due to high cycle time represented 19% of the total downtime for Injection Molding Area. This inefficiency was identified as one of the top areas of opportunities to increase the area output. Data gathered from January 2021 to July 2021 identified the top three machines.

Figure 2 shows the machines with the highest downtime due to high cycle time. The top three offenders of the 300 Ton Injection Machines were IM 37, IM 26, and IM 39. Each machine was in the range of 7 to 10 seconds over the standard time cycle.

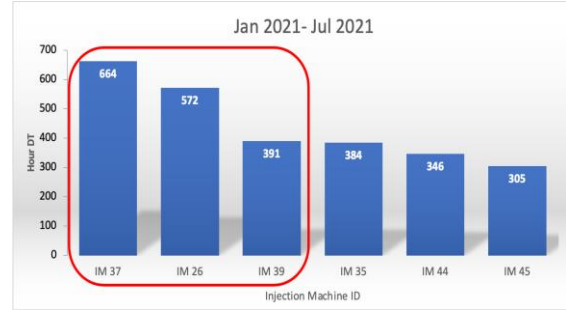

Figure 2
High Cycle Time Top Detractors

ANALYSIS

A deeper analysis required a root cause exercise to identify the possible causes of the cycle increase in the area.

The top possible causes of high cycle time identified by the multi-functional team were below the category of machine as showed in Figure 3:

- Machine poor condition
- Auxiliary equipment poor condition
- Obsolete technology

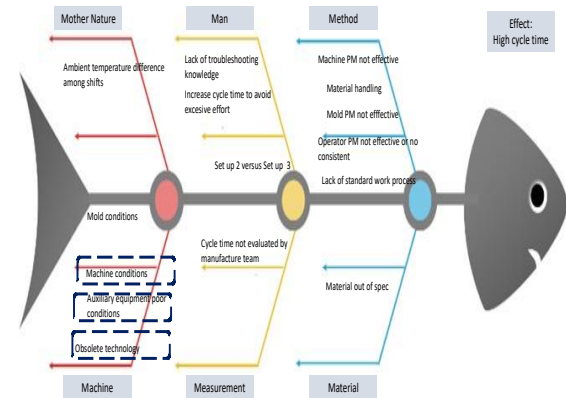

Figure 3
Fishbone Root Cause Diagram

After the evaluation the findings were:

- **IM-37:** issues to sustain clamping pressure during the molding process, the frequency drive required substitution to standardize the shot size, had issues with the thermolator and the screw and barrel needed replacement.
- **IM-26:** issues sustaining clamping pressure during the molding process, the frequency drive required to be replaced, and the elevator module were obsolete.

- IM-39:** had issues with the venting function that did not allow the machine to continue with the process, the thermolator turned off during the process not allowing to complete the heat exchange process in the mold, the elevator module was obsolete, and needed vacuum system.

RESULTS

In a collaboration with the maintenance team, the frequency drive was immediately replaced in IM-37 and IM-26, eliminating the discrepancies during the material shot size while the screw charging process. IM-37 clamping issues were corrected after screw and barrel replacement. For IM 39 the venting function was corrected once a program update was completed to the machine PLC system.

Obsolete modules were ordered and are expected to be received by the end of October to be replaced in IM-26 and IM- 39. Thermolator replacement and new vacuum system were included in the Capital Approval Request for 2022.

Figure 4 shows trend regarding downtime due to high cycle time for machine 37. Running hours during the month are showed in the orange bar, downtime hours are the blue bars. The line represents the percentage of downtime versus the running hours. After the corrections were made in August the trend was to the downtime decline. The lowest percentage were observed in September with a 3%.

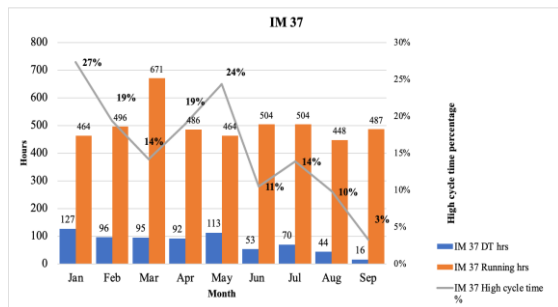

Figure 4

IM-37 High Cycle Time Downtime Trend

Figure 5 shows IM-26 trend of high cycle time downtime. In August the corrections made reflected

a huge improvement with a percentage difference of 9%. However, in September it was observed an increase up to 14% related to mold poor conditions. In October a different mold was installed in the machine, and the data showed a drop in downtime of 4%. Machine cycle was reduced from 41 seconds to 37 seconds.

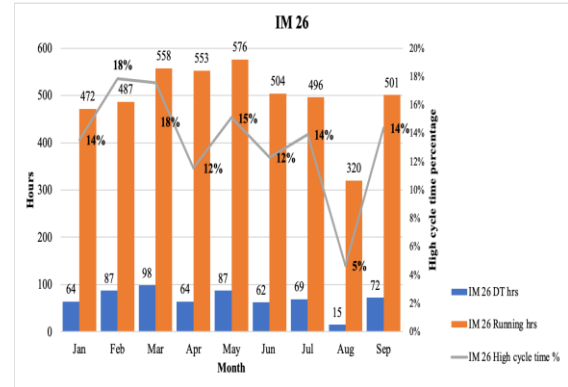

Figure 5

IM-26 High Cycle Time Downtime Trend

Figure 6 shows IM- 39 cycle time downtime behavior and trend. Corrections made in August reflected a reduction of 5% versus July results. September continued in a decrease trend with a 2%. This percentage was the lowest observed during 2021.

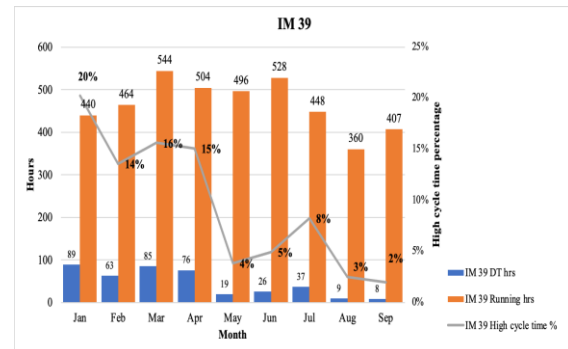

Figure 6

IM-39 High Cycle Time Downtime Trend

Equation (1) was used to calculate improvement.

$$Improvement = \frac{(a-b)}{a} \quad (1)$$

Table 1 represents the baseline data prior the machines evaluation, while Table 2 shows the

machines performance after the improvement were done. The average percentage contemplates the total running hours to normalize the data. When the information in Table 1 is compared with information in Table 2, it can be seen that a reduction in cycle time was achieved.

Table 3 shows the summary of the results after project completion. The final downtime percentage reflects that the project exceeded the goal of 10% reduction on each machine.

Table 1
Summary Data Jan-Jul 2021

Machine	Cycle time average Jan-Jul 2021	Average Running hours Jan-Jul 2021	Average percentage Jan-Jul 2021
IM-37	92	513	18%
IM-26	76	521	15%
IM-39	56	489	12%

Table 2
Data Summary After Corrections Aug-Sep 2021

Machine	Cycle time average Aug-Sep 2021	Average Running hours Aug-Sep 2021	Average percentage Aug-Sep 2021
IM-37	30	468	6%
IM-26	44	411	11%
IM-39	8.5	384	2%

Table 3
Final Downtime Improvement

Machine	Average percentage Jan-Jul 2021	Average percentage Aug-Sep 2021	Final downtime percentage improvement
IM-37	18%	6%	64%
IM-26	15%	11%	27%
IM-39	12%	2%	81%

CONCLUSION

Process parameters have an important role in the injection molding process, however, there are other factors that also affect the process. Variables such as

equipment conditions have a direct impact in the BMC molding process.

After project completion, machine performance reflected a reduction in high cycle time downtime after corrections were made. It was observed a 64% downtime reduction due to high cycle time in IM-37. In IM-26 it was observed a reduction of 27%. IM-39 reflected a reduction of 81% on the total hours down due to increased cycle time.

Downtime reduction on each equipment represented a 2% of increase of overall OEE of the area reaching a 58% which is 3% over the goal. Demand of the product requires to continue with the improvements in the area. During the progress of this project, other areas were identified for next projects such as the evaluation of mold PM effectiveness and machine PM effectiveness to ensure sustainability of the improvements achieved in this project. Finally, this information was presented to the Leadership team which evaluated the information and were satisfied with the results.

REFERENCES

- [1] Ning Guang Mold & Plastic Co., Ltd; SMC Mold Solution, (2013), *Injection Molding of BMC*; Available: [Injection Moulding of BMC \(smctooling.com\)](http://smctooling.com)
- [2] Tatara, Robert A., (2017), *Applied Plastics Engineering Handbook. 2nd Ed.*, Available: [Bulk Moulding Compound - an overview | ScienceDirect Topics](https://www.sciencedirect.com/topics/engineering/bulk-moulding-compound)
- [3] Plastic Mold Solution Provide; (2020), *BMC injection molding process for thermosetting plastics*; Available: [BMC injection molding process for thermosetting plastics - Knowledge - Odin Mould Co.,Ltd \(plasticomould.com\)](http://plasticomould.com)
- [4] Rev Part; *How to Minimize Cycle Time in Injection Molding*; Available: [How to Minimize Cycle Time in Injection Molding | Revpart](http://revpart.com)